

# Sigma II SERCOS Interface

**The new P730 Sigma II SERCOS Interface from Trio Motion Technology makes this leading digital drive communications standard available to users of the popular Yaskawa Sigma II Servo Drives.**

Specifically designed for servo drive control applications, the SERCOS interface can transmit cyclic data at high speeds with precise synchronisation.

SERCOS has the advantage of being an open standard, which allows drive and controller users to avoid being "locked in" to proprietary systems. The P730 can operate with third party motion controllers or with Trio's *Motion Coordinator* range.

The Sigma II Sercos Interface satisfies SERCOS Interface Specification compliance class B in velocity or position control mode, and can run at SERCOS cycle times of 500µsec and above.



**Module simply clips to any suitable Yaskawa Drive**

- ▲ **Standard drive communications**
- ▲ **Up to 16 MHz data rate**
- ▲ **Reduction of system wiring**
- ▲ **Centralised configuration**
- ▲ **Better diagnostics**
- ▲ **Higher performance**
- ▲ **Noise-free fibre-optic communications**

## SERCOS Interface Standard

### Serial Realtime COmmunications System

Standardised worldwide (IEC 61491 & EN 61491)

Open Standard, used by many different drive and controller manufacturers. Optical Fibre used as the transmission medium.

The P730 implements a CLASS B Slave SERCOS device. It does not currently support the class B drive controlled homing procedure IDNs. D'YUgY'WX'YW' h'Uh'h'Y' b'YW'ggUfm=8B'fj' UbX'Z' b'W]cbU' ]miUfY' Uj' U' ]UV'Y' cb' h'Y'D+' \$'Zcf'mci' f'Udd' ]W]h]cb'k' \Yb'i' g]b[ 'h' ]fX'dUf'mia' Ugh'Yfg''

## P730 Sigma II Interface Block Diagram

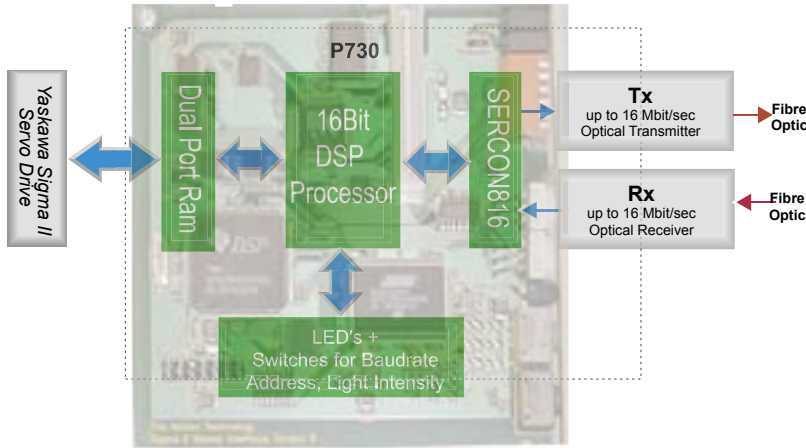

### Data Rate

DIP Switches on the front panel set 2, 4, 8 or 16 MBaud. Additional switches allow the transmission light intensity to be adjusted.

### Drive Address

The drive address on the SERCOS network is set via 2 rotary switches.

### LED Indicators

4 led indicators display the SERCOS phase, enable/disable and error status.

### Communication

The P730 Sigma II SERCOS Interface supports the velocity and position control modes of the SERCOS Interface specification, along with the configurable cyclic communication mode (using application telegrams). In addition, the drive can be controlled in torque mode by configuring the appropriate drive parameter and using the SERCOS velocity telegram. The Sigma II drive's velocity with torque feed forward mode is supported using the application telegrams.

- \* Transmission of nominal position IDN15 = 4
- \* Transmission of nominal speed IDN15 = 3
- \* Configurable transmission IDN15 = 7

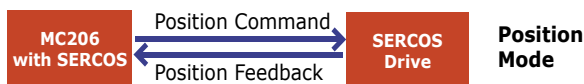

### Distributed By:

## Sigma II Interface Version 1

### Motion Coordinator

- Interpolation up to 24 axes
- Circular Interpolation
- Helical Interpolation
- Cam Profiles
- Software Gearboxes
- Linked Movement
- Axis Superimposition
- Imaginary Axes
- Hardware Registration

Any Axis can run any move type

### Drive Initialisation

The SERCOS Interface allows read and write access to all the Yaskawa drive parameters as manufacturer specific parameters.

### Servo Cycle

500µs minimum in velocity/torque mode. 1000µs minimum in position command mode. These minimum settings are determined by the drive rather than by the SERCOS interface.

### EMC

The P730 will meet EN55022: 1995 Class A radiated emissions and EN50082-2: 1995 industrial immunity standards when installed and used in accordance with the installation requirements.

### Ordering Information:

Product code: P730  
Sigma II SERCOS Interface



**Trio Motion Technology Ltd:**

**Trio Motion Technology LLC:**

Shannon Way, Tewkesbury, Glos. GL20 8ND. UK

1000 Gamma Drive, Suite 206, Pittsburgh PA 15238, USA.

Tel: +44 1684 292333 Fax: +44 1684 297929

Tel: +1 412.968.9744 Fax: +1 412.968.9746

Email: [sales@triomotion.com](mailto:sales@triomotion.com)

Website: [www.triomotion.com](http://www.triomotion.com)